



THM80X Series (THM801 / 802 / 803)

Temp & Humid.-THM80X

www.eyc-tech.com

Industrial High Accuracy Temp. & Humidity Transmitter



| Features |

- IP65, aluminum alloy casing for harsh environments
- Capable of temperature compensation, computer-driven linear adjustment for temperature and humidity, with analog output or optional RS-485.
- High-accuracy temperature and humidity measurement, fast response and quick recovery after condensation, excellent long-term stability in high humidity.
- Process Temp : Up to 200°C, S.S. probe pressure resistance : 10 bar, movable thread for repeatable installation.
- Units switchable : [%RH], [°C], [mbar], [g/kg], [g/m³], [kJ/kg].
- RS-485 connection for configuring parameters via planning software with DATA LOG function, recording up to 65535 entries for graphical analysis.

| Applications |

Semiconductor / Electronics / Industrial process monitoring / Air conditioning / Environmental ventilation control buildings / Factories / Hospitals / Clean rooms / Laboratories / Weather stations environmental monitoring / Storage rooms / Environmental chambers / Greenhouses / Mushroom farms / Paper / Printing / Textiles / Steel and iron industry / Food / Chemical / Pharmaceutical / Biotechnology industry

| Specification |

Input

Signal type Capacitive humidity sensor & Pt 100 A class

Output

Output 4 ... 20 mA / 0 ... 10 V / RS-485

Signal connection 3-wire

Display type LCD Module with back light, double line character

Display range upon request, one decimal place

Height of character 5.55 mm

Accuracy (at +25 °C)

Temperature $\pm 0.1^{\circ}\text{C} \pm 0.002^{\circ}\text{C} \times t_{\text{actual}}$

Humidity (0 ... 90 %RH) Nonlinear error : $\pm 1.2\% \text{RH}$

Hysteresis error : $\pm 0.8\% \text{RH}$

Repeatability error : $\pm 0.4\% \text{RH}$

Humidity (90 ... 100 %RH) $\pm 2\% \text{RH}$

Temp. influence 0.05%RH/°C

Load resistance Current output : Max. 500 Ω

Voltage output : min. 100 K Ω

Output calibration(ZERO & SPAN) Software

Response time t90 (at 25 °C) <20 sec (S.S.Metal grid filter with mesh)

<30 sec (Sintered filter)

*This accuracy specification is measured under on-site test conditions in a flow environment above 1 m/s, and verified in accordance with the factory' s ISO 9001 production and testing standards.

Electrical

Power supply DC 24 V $\pm 10\%$

Current consumption DC 24 V : 60 mA

Electrical connection M type : M12 connector with 2 m cable

N type : M16 metal cable gland and terminal block

Environmental

Medium Air

Temp. Operating Housing : -20 ... +80°C

Housing with display : -20 ... +60°C

Humid. Operating Housing : 0 ... 95% (Non-condensing)

Probe operating Wall type : -40 ... +80°C

Duct type : -40 ... +120°C

Remote type : -40 ... +200°C

Storage temperature -25 ... +60°C

Probe pressure resistance 10 bar

Certification

Certification CE

Protection

IP rating Housing : IP65 ; Probe : IP20

Electrical protection ■ Reverse polarity ■ Over-voltage ■ Short-circuit

Installation

Installation THM801 : Wall type

THM802 : Duct type

THM803 : Remote type

Material

Housing Aluminum alloy

Probe SUS 304

Remote probe cable TEFLON (Remote THM803)

Weight THM801 : 455 g / THM802 : 521 g / THM803 : 635 g

| Measuring Range List |

*Measurement ranges are converted based on Temp. and humidity, with values provided for reference only.
*The measurement range is defined at the standard condition(1013 mbar, 25°C).

Physical quantity	THM801 Wall type	THM802 Duct type	THM803 Remote type
Temperature(T)	-40°C ... +80°C	-40°C ... +120°C	-40°C ... +200°C
Humidity(H)	0 ... 100%RH		
Dew point(D)	-40 dp°C ... +60 dp°C		
Frost point(F)	-40 ... 0 fp°C		
Wet-bulb Temp.(W)	0 ... 100°C		
Vapor pressure(E)	0 ... 1100 mbar		
Mixture ratio(R)	0 ... 999 g/kg		
Absolute humidity(A)	0 ... 700 g/m ³		
Specific enthalpy(S)	0 ... 2800 kJ/kg		

| Calibration System |

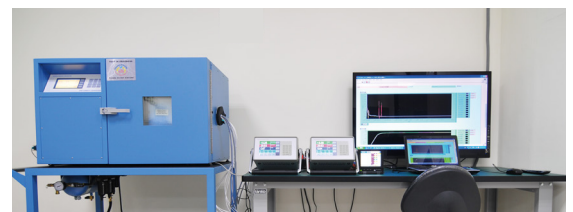

- System Facility
- Humidity generator
- Dew point mirror
- Laboratory level facility to produce products, and automatic QC inspection sheet printing and factory report

| Dimension |

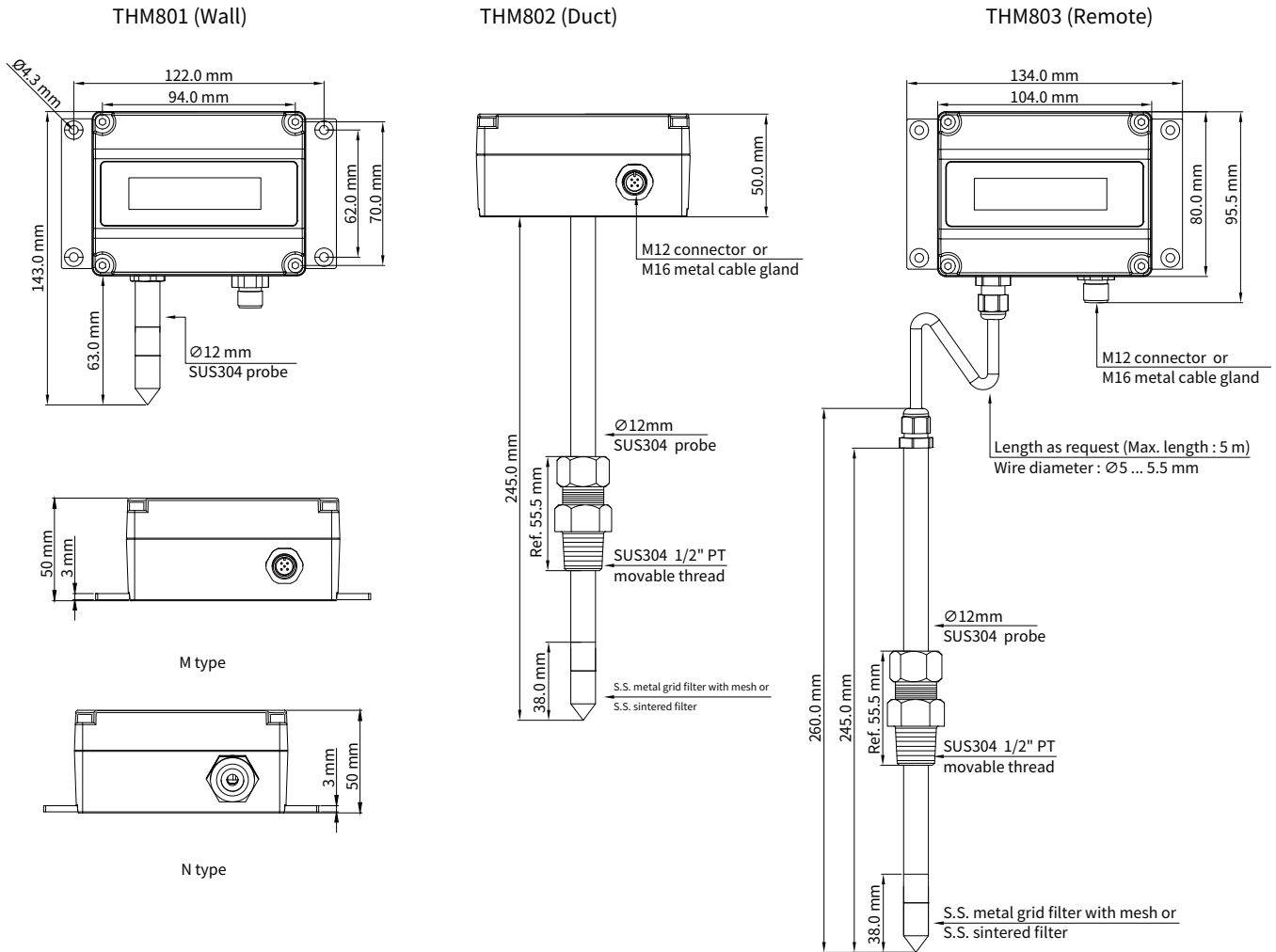

| Electric Connector | Unit : mm

【M type (M12-4PIN connector)
RS-485 or analog】

【M type (M12-8PIN connector)
RS-485+analog】

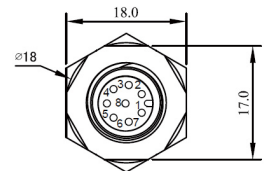
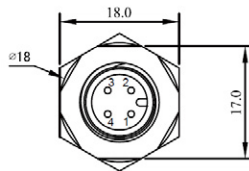
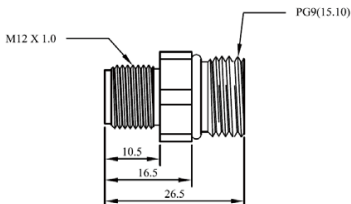

【N type (M16 cable gland)】

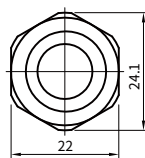
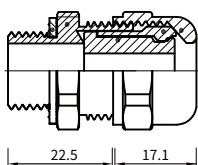

| 3-cycle curve |

※ According to IEC 61298 and ISO 17025 standard to measuring 3-cycle curve.
As the charts result, accuracy of test sample match with accuracy chart of humidity generator + dew point mirror

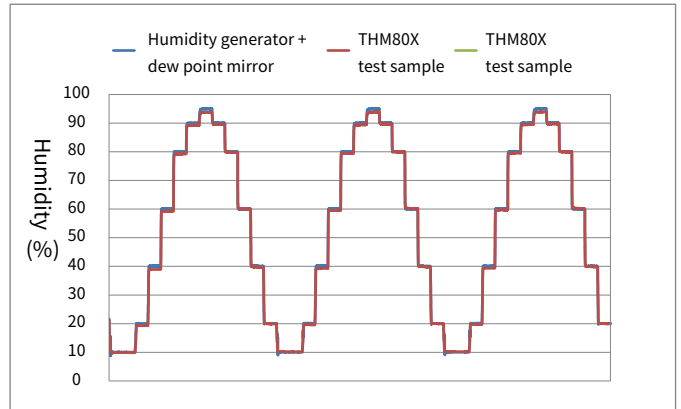
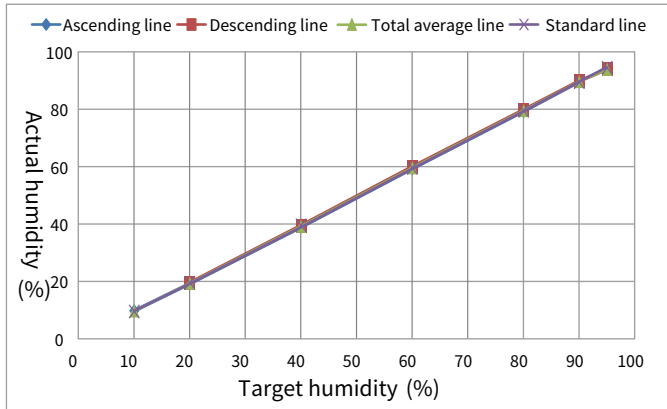

| Analog Diagram |

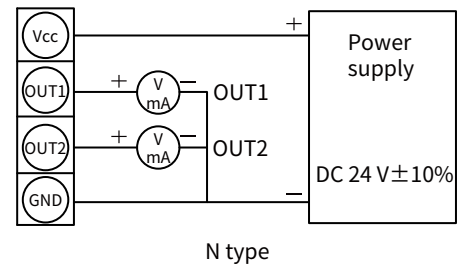
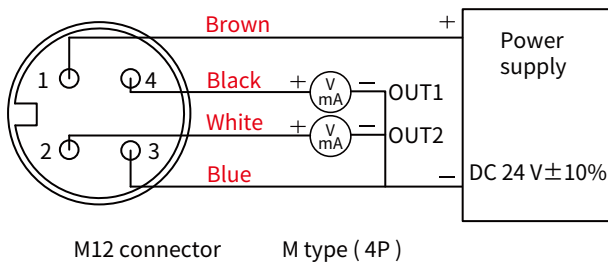

| RS-485 Diagram |

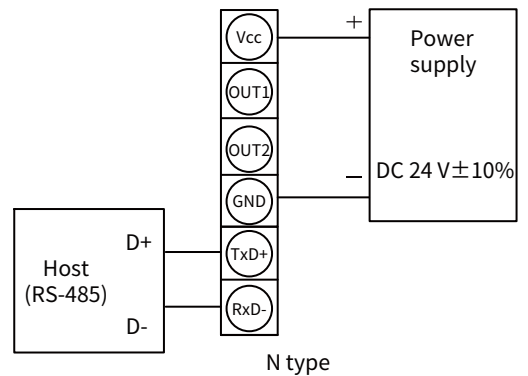
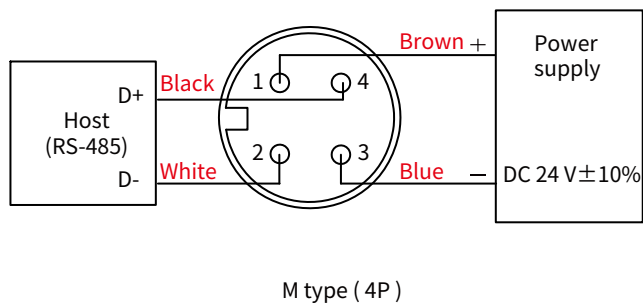

※ When output of ordering code is RS-485 (without analog), RS-485 diagram of default setting is M type.

| Analog+RS-485 Diagram |

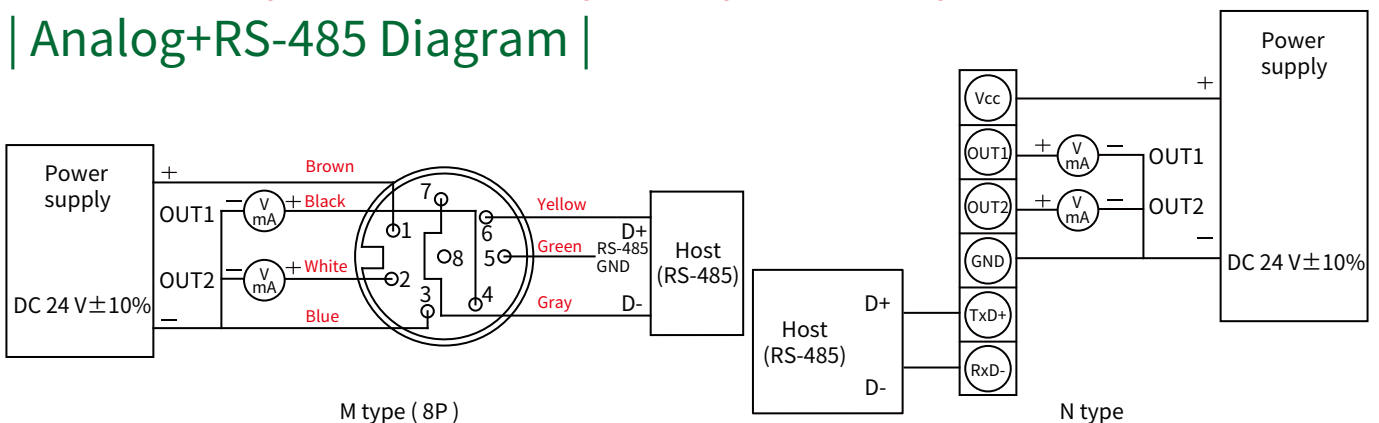

*Please make sure the product and the device which connect with RS-485 are on common ground, avoid damaged product.

| Ordering Guide |

THM80 **3** - **T** **48** **1** **H** **00** **1** - **D** **N** **S** **2** **U**

<p>Installation</p> <p>1 : Wall 2 : Duct 3 : Remote</p>	<p>Physical quantity output 1</p> <p>T : Temperature N : RS-485 setting (Default Temp.)</p>	<p>Physical quantity scale 1</p> <p>48 : 0 ... +180°C 47 : 0 ... +200°C 14 : -40 ... +60°C 16 : -40 ... +120°C 18 : -40 ... +180°C 20 : -40 ... +200°C 00 : RS-485 setting YY : Customized Temp. range (up to 200°C)</p>	<p>Signal output 1</p> <p>1 : 4 ... 20 mA 6 : 0 ... 10 V 9 : RS-485</p>	<p>Physical quantity output 2</p> <p>H : Relative humidity D : Dew point F : Frost-point W : Web-bulb temperature E : Vapor pressure R : Mixture ratio A : Absolute humidity S : Specific enthalpy N : RS-485 setting (Default Temp.)</p>	<p>Physical quantity output 2</p> <p>00 : As physical quantity measuring range list (Adjustable via RS-485)</p>	<p>Signal output 2</p> <p>1 : 4 ... 20 mA 6 : 0 ... 10 V 9 : RS-485</p>	<p>Display</p> <p>X : No D : Yes</p>	<p>Electrical connector</p> <p>N : M16 metal cable gland M : M12 connector</p>	<p>Filter</p> <p>S : Sintered filter M : S.S. metal grid filter with mesh</p>	<p>Remote probe cable</p> <p>2 : 2 m 5 : 5 m - : Customized (Max. length : 5 m)</p>	<p>Other request</p> <p>W : Other request (Quote as demand) U : RS-485 + analog</p>
--	--	---	--	--	--	--	---	---	--	--	--

*Recommended best-selling

Product ordering number	Product Specifications
THM803-T481H001-XMS5U	Remote type, CH1 : T, 0 ... +180 °C / CH2 : H, 0 ... 100%, O/P : 4 ... 20 mA, M12, 5 m TEFLON cable, Sintered filter
THM803-T481H001-DMS5U	Remote type + display, CH1 : T, 0 ... +180 °C / CH2 : H, 0 ... 100%, O/P : 4 ... 20 mA + RS-485, M12, 5 m TEFLON cable, Sintered filter

| Additional Option Test Report | For more detailed information please contact us.

■ ILAC / TAF

YUDEN-TECH CO.,LTD. Calibration Laboratory - (ILAC / TAF) Test report.
(TAF accreditation : 3032, complying with ISO / IEC 17025) TAF has mutual recognition arrangement with ILAC MRA

Project	Measurand level or range
Hygrometer	Temperature : 0°C ... 69.5°C
	Humidity : 10% ... 95%
Project	Measurand level or range
Dew point transmitter	≥ -80 dp°C ... ≤ 60 dp°C

■ ISO 9001

Project	Measurand level or range
Temperature and Humidity	Temperature : 0°C ... 200°C
	Humidity : 0.1% ... 99.8%
Project	Measurand level or range
Dew point	≥ -95 dp°C ... ≤ 60 dp°C